

MY 2006 M-CLASS MODEL RANGE



Mercedes-Benz

ML 350	Released March 2005	\$39,750 ¹
ML 500	Released March 2005	\$48,500 ¹

¹ = Does not include destination and delivery



Positioning

Class

- The all-new ML-Class is dynamically crafted to master your on-road lifestyle.

Rationale

- Speaks to the fact that the major improvements are in both on-road performance and modern, dynamic styling
- Transitions from more off-road orientation to on-road comfort and handling
- Speaks to quality build

Model

- ML350
 - The all new ML350 is strikingly different from all angles both outside and inside. It fuses the ideal balance between the use of space expected from a 5 passenger SUV with the performance and agility of an advanced on road utility vehicle.
- ML500
 - The all new ML500 personifies the thrill seeker, wrapped around an aerodynamic skin with a stylish and inviting interior fit for the discerning shopper who expects luxury at its finest.



Ordering Overview - ML350/500 Base Model

ML350/500 Base Model

 Mercedes-Benz

ML350



- Privacy Glass/Roof Rails not Included



- Standard 17" V6 Wheel



- Standard Grill

ML500



- Privacy Glass
- Roof Rails
- Blue Glass in Front Windows

Chrome:

- Door Handles
- Tailgate Trim
- Side Molding
- Squared Dual Exhaust Tips



- Standard 18" V8 Wheel



- Silver Painted/Chromed Grill
- Brushed Chrome Skid Plates

ML350



- Cloth Inserts w/ MB Tex
- Aluminum Trim





- Leather Inserts w/ MB Tex
- Burl Walnut Wood Trim
- Tele Aid/Homelink



Ordering Overview - ML350 Trim Package (Code 318)

ML350 Trim Package (Code 318)



- 
 - Privacy Glass
 - Roof Rails
- 
 - Standard 17" V6 Wheel
- 
 - Standard Grille
- 
 - Leather Inserts w/ MB Tex
 - Brown Birds-Eye Wood Trim
 - Tele Aid/Homelink
- 
- 

***Available on ML350 Only**



Ordering Overview - ML350/500 Premium Package (Code 326)

ML350/500 Premium Package (Code 326)



ML350



- Privacy Glass
- Roof Rails



- Standard 17" V6 Wheel



- Standard Grille

ML500



- Privacy Glass
- Roof Rails
- Chromed Accents
- Blue Glass in Front Windows



- Standard 18" V8 Wheel



- Silver Painted/Chromed Grille
- Brushed Chrome Skid Plates

ML350/500



- Leather Seating Surfaces
- Burl Walnut Wood Trim
- Tele Aid/Homelink
- Premium Interior Lighting
- Power Lift Gate

- Wood/Leather Steering Wheel
- Multi-Contour Seats
- DVD Navigation



Ordering Overview - ML350/500 Appearance Package (Code 322/422)

ML350/500 Appearance Package (Code 322/422)



ML350/500

- Privacy Glass
- Roof Rails
- Blue Glass in Front Windows

- Chrome:
- Door Handle
 - Tailgate Trim
 - Side Molding
 - Squared Dual Exhaust Tips



•19" Aluminum Sport Wheel
(or)



•19" Chromed Sport Wheel

ML350



- Silver Painted/Chromed Grill

ML500



- Silver Painted/Chromed Grill
- Brushed Chrome Skid Plates

ML350/500













- Sport Instrument Cluster
- Aluminum/Rubber Studded Sport Pedals
- Alcantara Inserts w/ MB Tex
- Tele Aid/Homelink

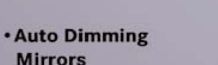

Ordering Overview - Popular Option Packages

 Mercedes-Benz

Popular Option Packages

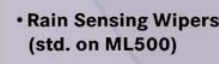
Comfort (Code 317)	Lighting (Code 319)	Entertainment (Code 320)	Air Suspension (Code 323)	Sunroof (Code 324)
 <ul style="list-style-type: none">• Memory Seats  <ul style="list-style-type: none">• Power Folding Mirrors  <ul style="list-style-type: none">• Auto Dimming Mirrors• Power Steering Column• Interior Cargo Rails w/ Cargo Management System• Cargo Net/Cover	 <ul style="list-style-type: none">• Bi-Xenon Lights w/ Headlamp Washers• Active Curve-Illuminating Headlights  <ul style="list-style-type: none">• Corner-Illuminating Front Foglamps	 <ul style="list-style-type: none">• harman/kardon Logic 7 System  <ul style="list-style-type: none">• Glovebox 6-Disc CD Changer (MP3 Capable)	 <ul style="list-style-type: none">• Adjustable Height Air Suspension  <ul style="list-style-type: none">• Active Damping Shocks• Parameter Steering (std. on ML500)	 <ul style="list-style-type: none">• Electric Sunroof  <ul style="list-style-type: none">• Rain Sensing Wipers (std. on ML500)

*AMG Sport Package & Stand Alone Options not shown.



Option Matrix and Trim/Upholstery overview

Option Package Matrix - ML350

Step 1:
All Packages require
Sunroof Pkg.

Step 2:
Choose
1 of 3
Upholsteries

Step 3:
Add Any
of the
Following

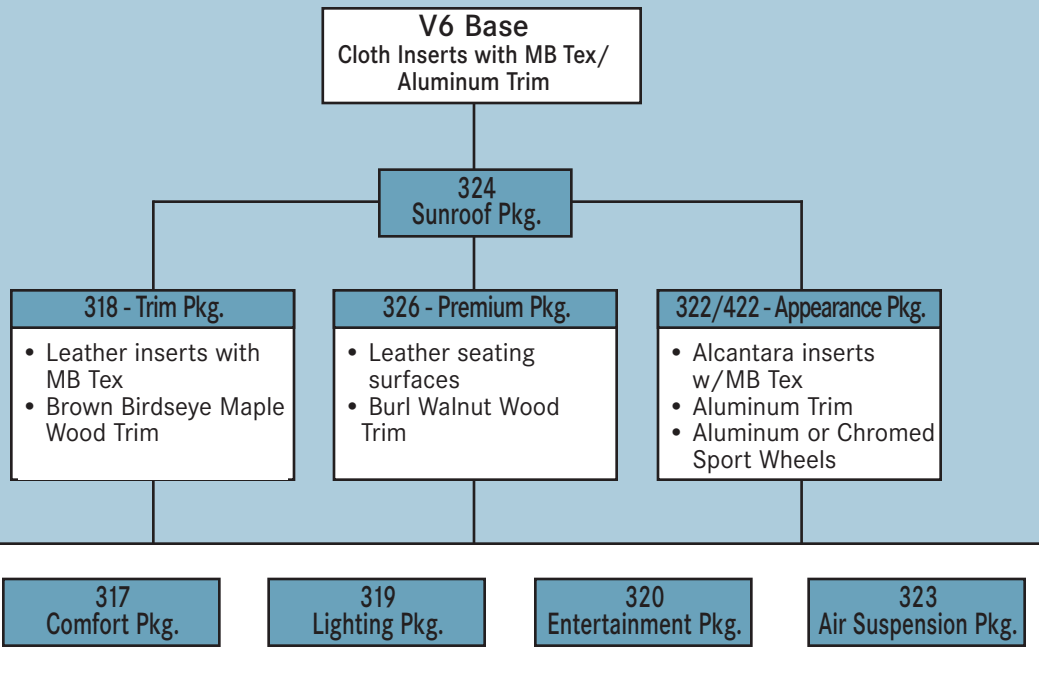

321
AMG Pkg.

N/A
Appearance
Package



Option Matrix and Trim/Upholstery overview

Option Package Matrix - ML500

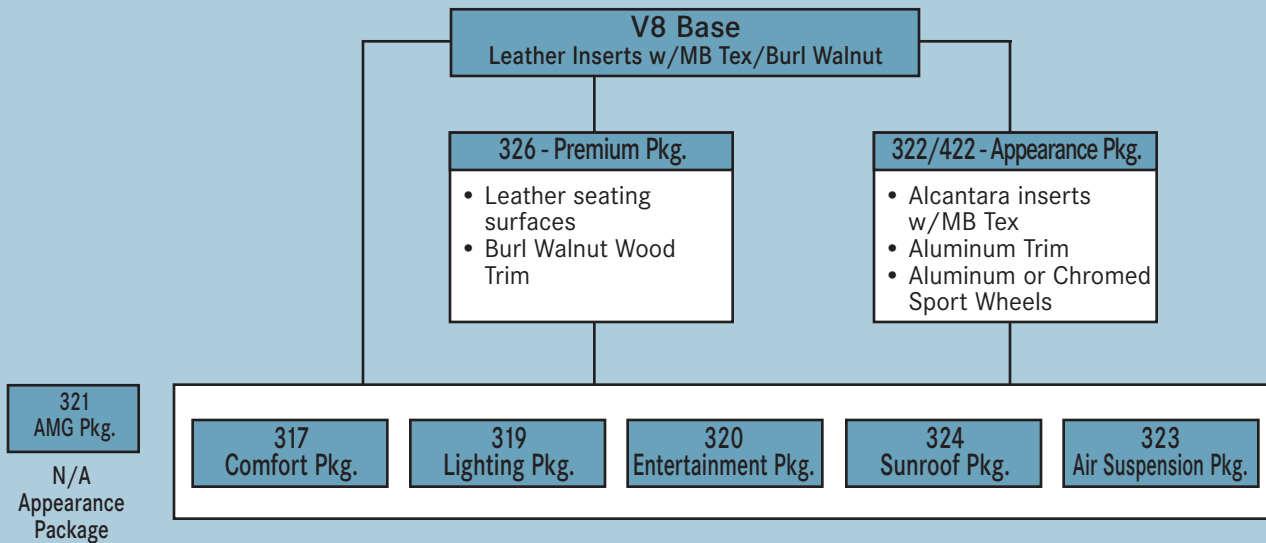

MY 2006 M-CLASS





Mercedes-Benz

Optional Equipment Availability

Code	Optional Equipment	ML 350	ML 500
(A)	Metallic Paint	\$690	\$690
220	Parktronic ⁽¹⁾	\$750	\$750
293	Rear Sidebags ⁽¹⁾	\$385	\$385
530	DVD Navigation ^{(1),(2)}	\$1,240	\$1,240
536	SIRIUS Satellite Radio ⁽¹⁾ - includes 6 month subscription. Factory installed only.	\$500	\$500
550	Trailer Hitch ⁽¹⁾	\$490	\$490
581	Thermatronic - 3 Zone Climate Control ⁽¹⁾	\$750	\$750
873	Heated Front Seats ⁽¹⁾	\$690	S
889	Keyless Go ⁽¹⁾	-	\$1,080
890	Power Tailgate ^{(1),(2)}	\$520	\$520
R38	18" 5-Doublespoke Wheel ⁽¹⁾ (see Wheel page M20)	\$900	\$250 (18" Wheel Std)

Marshalling Yard Accessories

052	Roof Rack Basic Carrier 	\$228	\$228
053	Cargo Area Tray and Cargo Box 	\$178	\$178

(A) = Refer to paint and upholstery matrix for individual codes
 S = Standard Equipment
 O = Optional Equipment
 - = Not Available

⁽¹⁾ = Requires Premium , Appearance or Trim Package (all packages require Sunroof Package (324))
⁽²⁾ = Also included in Premium Package



Option Package Availability

Code	Option Packages	ML 350	ML 500
Step 1	All Packages require Sunroof Package (324)		
324	Sunroof Package: Electric Sunroof and Rain Sensing Wipers†	\$1,390	\$1,290
Step 2	Choose one of the following Packages:		
318	Trim Package: Not available with Appearance Package. Leather inserts with MB Tex, Brown Bird's Eye Maple Wood Trim (ML500 gets Burl Walnut Wood Trim), Privacy Glass, TeleAid, Roof Rails and Homelink. Requires Sunroof Package.	\$2,200	S
322	Appearance Package: Not Available with Premium Package, Trim Package and AMG Sport Package. Sport Exterior/Interior, 19" Aluminum Sport Wheels, Sport Pedals, Silver painted/Chromed Grill, Chromed Door Handles, Side Molding, Tailgate Trim, Sport Seats (Alcantara inserts with MB Tex), Premium Interior Lighting, Blue Glass† for front two windows and windshield (Privacy Glass all other windows), Sport Instrument Cluster, Standard Bumpers, TeleAid†, Homelink† and Roof rails†	\$2,550	\$950
422	Appearance Package with Chrome Wheels: Appearance Package (322) plus 19" Chrome Wheels Sport. Not available with Premium Package, Trim Package and AMG Sport Package.	\$3,350	\$1,750
326	Premium Package: Not Available with Appearance Package. Includes Trim Package. Leather seating surfaces (replaces leather inserts with MB Tex), Burl Walnut Wood (replaces Brown Bird's Eye Wood), Premium Interior Lighting, Power Liftgate, Wood/Leather Steering Wheel, Multi-contour Front Seats, DVD Navigation.	\$6,150	\$3,750
Step 3	Requires either Trim Package (318) or Premium Package (326)		
321	AMG Sport Package: Not Available with Appearance Package or Appearance Package with Chrome Wheels. Silver Painted Chromed Grill†, Unique Front/Rear Bumpers, Chromed/Squared Dual Exhaust Tips, 19" AMG 5-spoke polished Alloy Wheels.	\$4,500	\$4,200
Additional Packages:	Requires either Trim Package (318), Appearance Package (322/422) or Premium Package (326)		
317	Comfort Package: Auto-dimming mirror, Memory Seats/Mirrors, Power folding mirrors, Power steering column, Cargo Rails with Cargo Management System and Cargo Cover/Net†	\$1,450	\$1,450
319	Lighting Package: Bi-Xenon Lights with headlamp washers, Active Curve-illuminating Headlights, Corner-illuminating Front Foglamps	\$890	\$890
320	Entertainment Package: harman kardon Logic7 System (MP3 capable), Glovebox 6-disc CD Changer	\$1,080	\$1,080
323	Air Suspension Package: Adjustable Air Suspension (plus 3-4" ground clearance), Active Damping Shocks (with sport and comfort settings) and parameter steering.	\$1,775	\$1,575

O = Optional Package
S = Standard Equipment
† = Standard on V8 models



Standard and Special Order Paint and Upholstery Matrix

ML350	Standard		Trim Package			Premium Package			Appearance Package	
Interior ▶	Black Cloth Inserts w/ MB Tex (001)	Ash Cloth Inserts w/ MB Tex (008)	Black Leather Inserts w/ MB Tex (101)	Ash Leather Inserts w/ MB Tex (108)	Macadamia Leather Inserts w/ MB Tex (104) ⁽³⁾	Black Leather (201)	Ash Leather (208)	Macadamia Leather (204) ⁽³⁾	Black Alcantara Inserts w/ MB Tex ⁽²⁾ (901)	Ash Alcantara Inserts w/ MB Tex ⁽²⁾ (908)
Trim ▶	Aluminum (739)	Aluminum (739)	Brown Birds Eye Maple Wood (H04)	Brown Birds Eye Maple Wood (H04)	Brown Birds Eye Maple Wood (H04)	Burl Walnut (731)	Burl Walnut (731)	Burl Walnut (731)	Aluminum (739)	Aluminum (739)
Exterior ▼										
Black (040)	X	X	X	X	X	X	X	X	X	X
Obsidian Black* (197)	X	X	X	X	X	X	X	X	X	X
Alpine Rain* (349)	X	X	X	X	X	X	X	X	X	X
Capri Blue* (359)	X	X	X	X	X	X	X	X	X	X
Verde Brook* ⁽¹⁾ (474)	X	X	X	X	X	X	X	X	X	X
Barolo Red* (544)	X	X	X	X	X	X	X	X	X	X
Desert Silver* (693)	X	X	X	X	X	X	X	X	X	X
Pewter* (723)	X	X	X	X	X	X	X	X	X	X
Iridium Silver* (775)	X	X	X	X	X	X	X	X	X	X
Everest Green* (816)	X	X	X	X	X	X	X	X	X	X
Alabaster White (960)	X	X	X	X	X	X	X	X	X	X

X = Standard Offering

* = Metallic Paint

BOLD = New Colors for MY 2006

⁽¹⁾ = Delayed Availability

⁽²⁾ = Alcantara - simulated Suede

⁽³⁾ = Macadamia - replaces Java, slightly darker shade



Standard and Special Order Paint and Upholstery Matrix

ML500	Standard			Premium Package			Appearance Package	
Interior ▶	Black Leather Inserts w/ MB Tex (101)	Ash Leather Inserts w/ MB Tex (108)	Macadamia Leather Inserts w/ MB Tex (104) ⁽³⁾	Black Leather (201)	Ash Leather (208)	Macadamia Leather (204) ⁽³⁾	Black Alcantara Inserts w/ MB Tex ⁽²⁾ (901)	Ash Alcantara Inserts w/ MB Tex ⁽²⁾ (908)
Trim ▶	Burl Walnut (731)	Burl Walnut (731)	Burl Walnut (731)	Burl Walnut (731)	Burl Walnut (731)	Burl Walnut (731)	Aluminum (739)	Aluminum (739)
Exterior ▼								
Black (040)	X	X	X	X	X	X	X	X
Obsidian Black* (197)	X	X	X	X	X	X	X	X
Alpine Rain* (349)	X	X	X	X	X	X	X	X
Capri Blue* (359)	X	X	X	X	X	X	X	X
Verde Brook* ⁽¹⁾ (474)	X	X	X	X	X	X	X	X
Barolo Red* (544)	X	X	X	X	X	X	X	X
Desert Silver* (693)	X	X	X	X	X	X	X	X
Pewter* (723)	X	X	X	X	X	X	X	X
Iridium Silver* (775)	X	X	X	X	X	X	X	X
Everest Green* (816)	X	X	X	X	X	X	X	X
Alabaster White (960)	X	X	X	X	X	X	X	X

X = Standard Offering

* = Metallic Paint

BOLD = New Colors for MY 2006

⁽¹⁾ = Delayed Availability

⁽²⁾ = Alcantara - simulated Suede

⁽³⁾ = Macadamia - replaces Java, slightly darker shade



Product Highlights

Standard Key Product Features:

- Unibody design for maximum on-road comfort, handling and body fit/finish
- Front & rear independent suspension
- All new 4 valve 3.5L V6 engine @ 268 hp; 3 valve 5.0L V8 engine @ 302 hp
- 7-Speed transmission with column shifter and steering wheel shift buttons

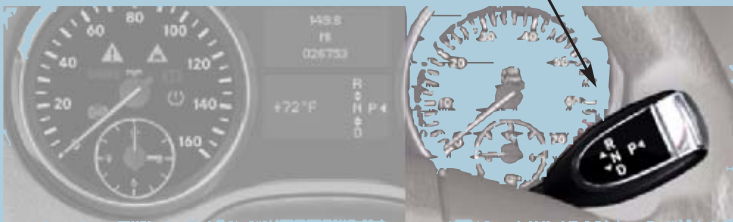

- Permanent 4WD
- Standard 17" V6 Wheel, Standard 18" V8 wheel (see wheel page)
- Multi-function steering wheel (wood/leather is optional)
- Multi-function instrument cluster display
- MCS 2 system, aux. plug - MP3 capable (optional CD Changer in glovebox)
- 2 - 32oz. Cupholders in center console
- Power Front Seats and Power Windows
- Downhill Speed Regulator and Hill-Start Assist
- 2-step folding rear seat
- No 3rd row seat option or power pop-out windows available

Thermatic - Standard 2-zone climate control for front driver/passenger with rear blower

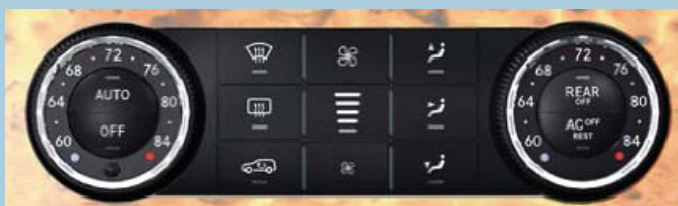

Thermotronic - Optional 3-zone climate control for front driver/passenger with separate temperature control for rear passengers included with rear blower





Product highlights - Exterior



ML 350 Appearance Package shown



Product highlights - Exterior



ML 350 Appearance Package shown

Squared Dual Exhaust



Product highlights - Interior/Exterior

Premium Package

Multifunction Steering Wheel

Column Shifter

Window Switches

2 large Cupholders

Macadamia (New color)



Appearance Package

Multifunction Instrument Cluster

Aluminum Trim

Alcantara Inserts with MB Tex





Product highlights - New Exterior Colors

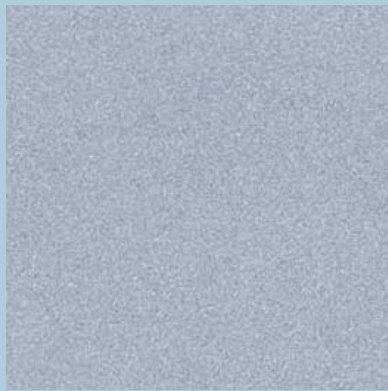

Alpine Rain* (Code 349) - Lighter than Platinum Blue



Verde Brook* (Code 474) (delayed availability) - A dark green with golden brown



Barolo Red* (Code 544) (delayed availability) - Darker than the current Bordeaux Red



Product Highlights - Wheel Designs

Factory Standard Wheels

ML 350
Standard 17" V6 Wheel
225/65 R17



ML500
Standard 18" V8 Wheel
255/55 R18



Factory Optional Wheels

18" 5-Doublespoke Wheel
(Code R38)
225/55 R18



Appearance Package

19" Aluminum Sport Wheel
(Code 322)
255/50 R19



19" Chromed Sport Wheel
(Code 422)
255/50 R19



OR

Accessory Wheels

18" 5-Spoke Wheel
225/55 R18



B6 647 4297

19" 6-Twin Spoke Wheel
225/50 R19



B6 647 4300



Product Highlights

ML500 Standard Equipment vs ML350

- 5.0L V8 engine @ 302 hp
- Trim Package
- Heated Seats
- Standard 18" V8 Wheel
- Silver painted grille with chrome ribs
- Chrome door handles, tailgate trim, side molding and squared dual exhaust tips
- Blue tinted sport glass for front two windows and windshield and privacy glass for rear windows
- Burl walnut wood trim
- Parameter steering
- Rain Sensing Wipers
- Brushed chrome skid plates
- Cargo net



Modifications: All New ML vs. Previous Generation

New - Complete Redesign:

- Unibody construction (saves weight, maximum comfort and on-road handling)
- Multifunction steering wheel
- 5-seater
- All-new 3.5l engine, 4 valve per cylinder 268 hp
- 7-speed transmission with column shifter and shift buttons located on the steering wheel
- Single-speed transfer case

- Window lifts control on the door panel for better access and comfort

- Multi-function display in instrument cluster

- All new interior & exterior design, materials, layout and equipment
- 2nd generation Modular COMAND headunit with single CD slot & auxiliary input (for MP3 players, i-Pods, etc.)
- Power seats standard
- 1-step folding 2nd row seats
- Lockable glove box
- Optional 18" 5-doublespoke wheel and 19" Sport Wheel (aluminum or chromed)
- Bigger brakes offer improved stopping:
 - V6 Front Brake 13" vs 11.8"
 - V8 Front Brake 13.8" vs 13.6"
- 6" longer than current ML
- 2" wider than current ML
- 4" longer wheelbase than current ML
- 2 - 3" more front leg room
- Downhill Speed regulator
- Hill Start Assist

Old:

- Ladder Frame

- Standard Steering wheel
- Optional 7-seater
- 3.7l engine, 3 valve per cylinder 232 hp
- 5-speed touchshift trans with center console-mounted stickshift
- 2-speed transfer case

- Window lifts in center console

- No multi-function display in instrument cluster

MY 2006 M-CLASS



Mercedes-Benz

Specifications - ML350*

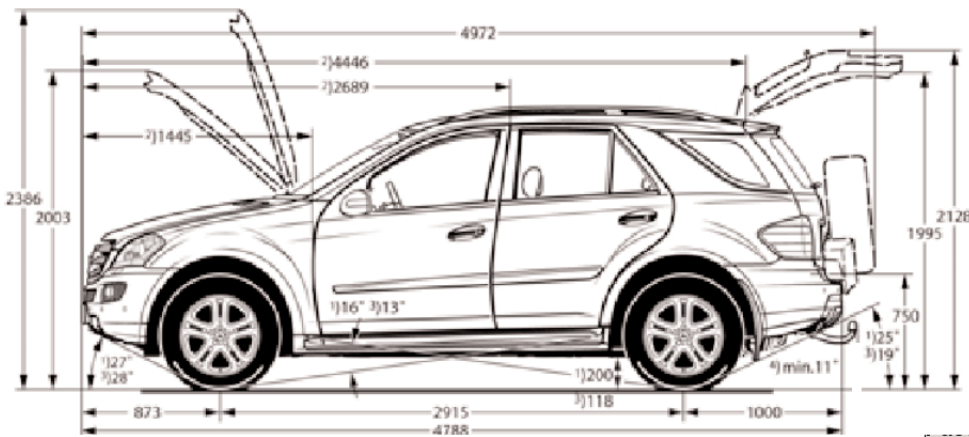

ML350

Body Style:	SUV
Passenger Capacity:	5
Construction:	Unibody
Engine:	3.5L V8
Engine hp/torque:	258/258
Transmission:	7 speed
Drivetrain:	Perm. 4WD
Length:	188.5 in.
Width:	75.3 in.
Height:	69.8 in.
Wheelbase:	114.7
Tow Capacity:	5,000 lbs.
Weight:	4,570 lbs.

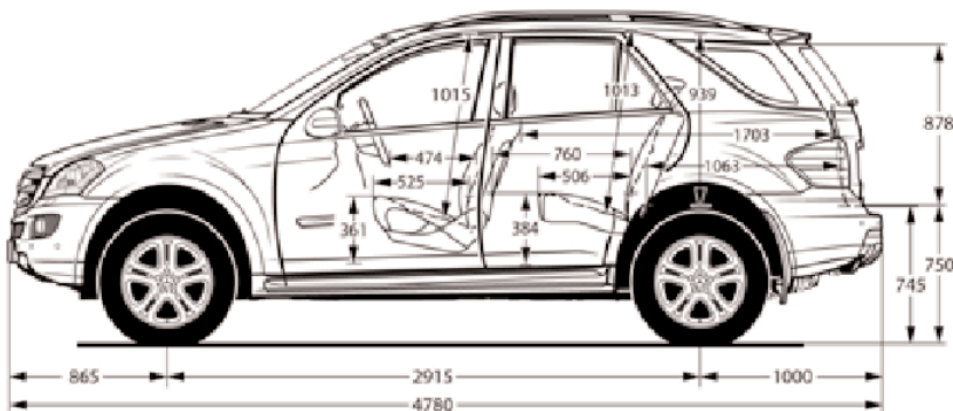

* = Dimensions shown are in metric units



Specifications - ML500*

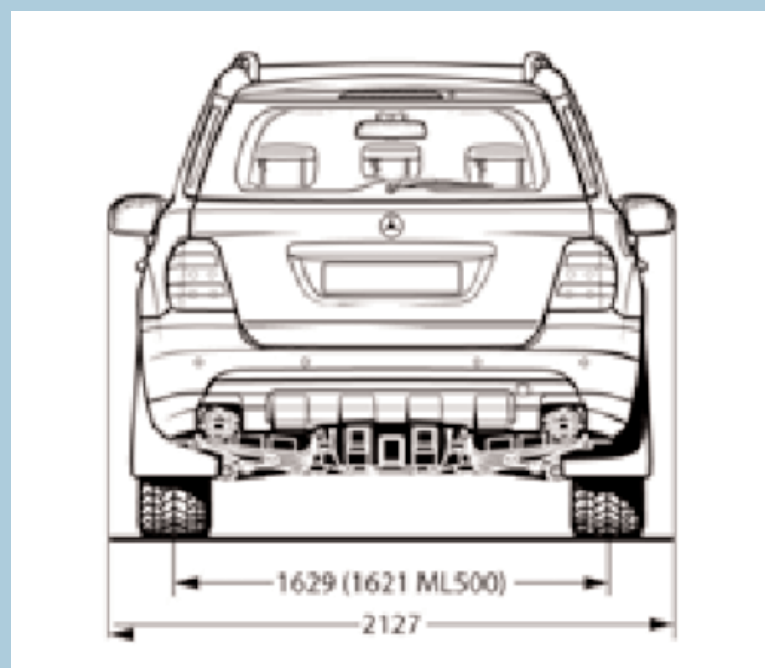
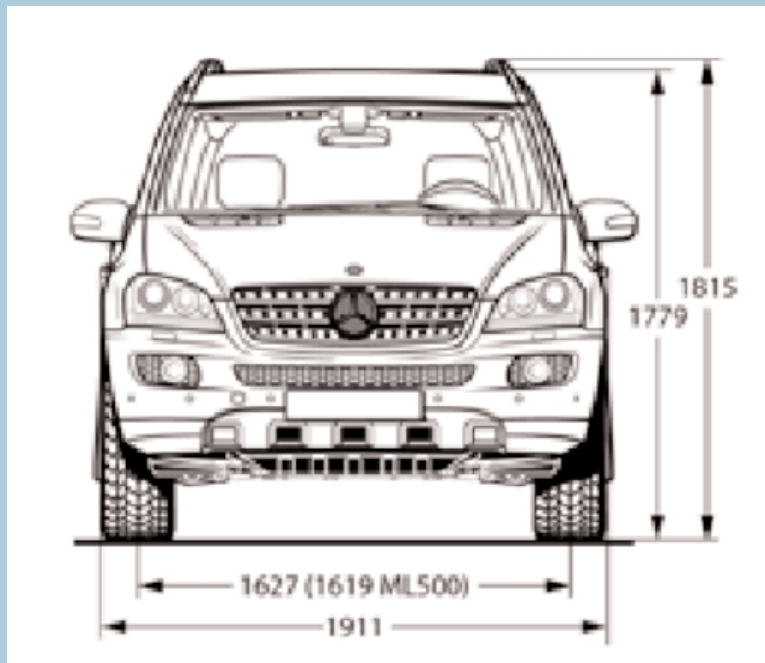

ML500

Body Style:	SUV
Passenger Capacity:	5
Construction:	Unibody
Engine:	5.0L V8
Engine hp/torque:	302/339
Transmission:	7 speed
Drivetrain:	Perm. 4WD
Length:	188.5 in.
Width:	75.3 in.
Height:	69.8 in.
Wheelbase:	114.7
Tow Capacity:	5,000 lbs.
Weight:	4,570 lbs.

* = Dimensions shown are in metric units



ML350 & ML500 Engine Specifications

	<u>ML350</u>
Engine:	3.5L V6
Engine hp / torque:	268 / 258



	<u>ML500</u>
Engine:	5.0L V8
Engine hp / torque:	302 / 339





Safety Features

Class Leading Standard Safety Features

Standard Safety Features

Crash Sensor:

Triggers the restraint system, such as the belt system and airbags, also unlocks the doors and switches on the interior lights and hazard flashers

Roll-over sensor:

Minimizes the effects of roll-over by triggering occupant protection system. If the sensor detects the car is rolling over sideways, the seat belt tensioners and both window airbags are automatically activated

Restraint System:

- Newly developed ARCADE control unit (electronically controls restraint system)
- 2-stage front passenger and driver airbags
- 1st and 2nd row window airbags
- Head restraint for all seats

Hill-Start Assist:

Maintains brake pressure for approximately 2 seconds after brake pedal is released (facilitates the transition from the brake pedal to the accelerator without the vehicle rolling backwards)

Downhill Speed Regulator:

Ability to maintain a constant speed of between 4-10 mph when traveling downhill via the multi-function steering wheel

- 4ESP®/4ETS Stability Control
- ABS
- BAS (Brake Assist System)
- Tire Pressure monitoring system
- Anti - Theft



Airbag Systems



Safety Features

Class Leading Standard Safety Features

Significant increase in collision safety through new rigid, integral body design

- Solid reinforced frames in the sidewalls and equally strong cross members in the doors results in a highly effective occupant protection
- Maximum possible resistance to deformation and larger deformation paths achieved through a number of measures:

- floor assembly with tunnels made of thicker sheet-steel
- strong cross member and diagonal member
- rear-seat cross member with additional reinforcement
- cross member below dashboard bolted to both A-pillars and tunnel

